

ADJUSTMENT

1. **ADJUST HEIGHT CONTROL SENSOR (IN CASE OF USING LEXUS HAND-HELD TESTER)**
 - (a) Connect the LEXUS hand-held tester to DLC3 on the vehicle.
 - (b) Start the engine and push the height control select switch to adjust the vehicle height to the "LO" then to "N" position.

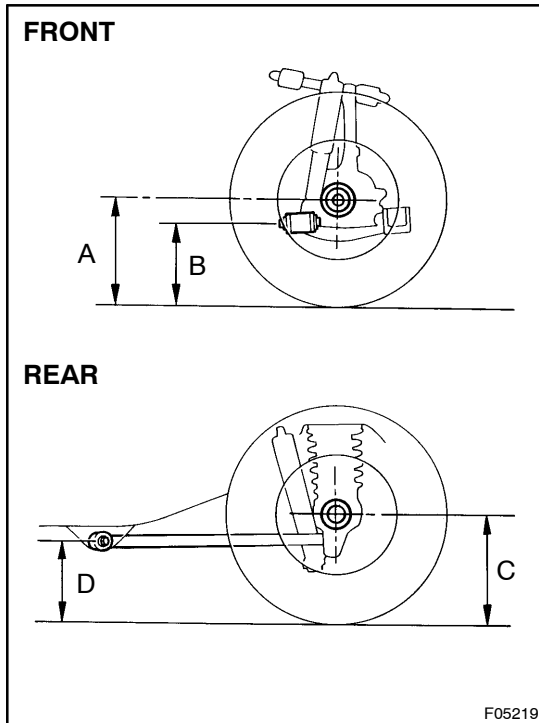

- (c) Inspect the vehicle height.

Vehicle height

Front	A - B: 82.7 mm (3.256 in.)
Rear	C - D: 71.2 mm (2.803 in.)

Measuring points:

- A: Ground clearance of spindle center
 B: Ground clearance of lower suspension arm front bolt center
 C: Ground clearance of rear axle shaft center
 D: Ground clearance of lower control arm front bolt center

- (d) Inspect and adjust the height control sensor to the neutral position.

- (1) Read the value of height control sensor on the LEXUS hand-held tester.

Standard value:

Actual vehicle height \pm 5 mm (0.20 in.)

HINT:

(Example)

When the measurement value of the front vehicle height is 85.0 mm (3.35 in.), the actual value of height control sensor is -2.3 mm (-0.09 in.).

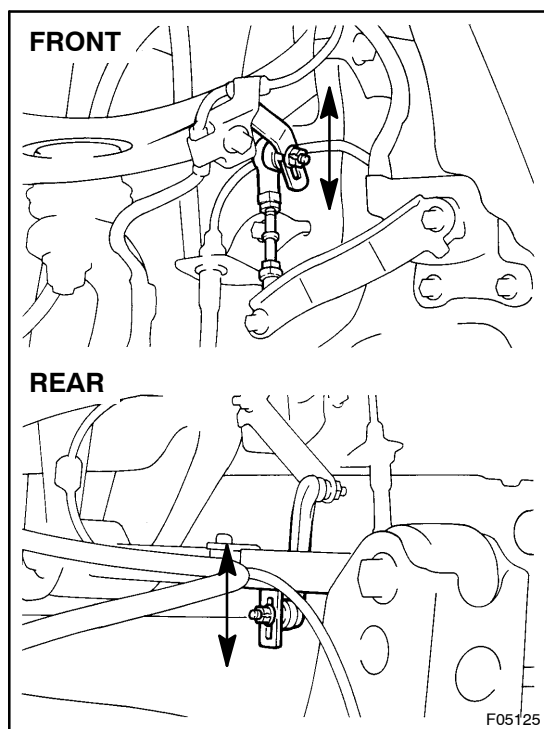

- (2) Loosen the nut and adjust the positions of the height control sensor link and front upper suspension arm or rear lower control arm by moving them up and down to install them.
- (3) Tighten the nut.

Torque: 5.6 N·m (57 kgf·cm, 49 in·lbf)

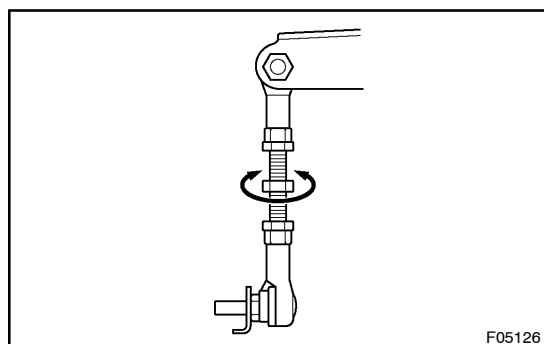

- (4) Front sensor:
When adjustment cannot be done by performing step (2), loosen the 2 nuts of height control sensor link and turn the link.

HINT:

- To raise the vehicle, turn the link clockwise.
- To lower the vehicle, turn the link counterclockwise.

- (5) Tighten the 2 nuts.

Torque: 5.4 N·m (55 kgf·cm, 48 in·lbf)

- (6) Coat the threads of the link with sealer.

Sealer:

Part No. 08833-00070, THREE BOND 1324 or equivalent

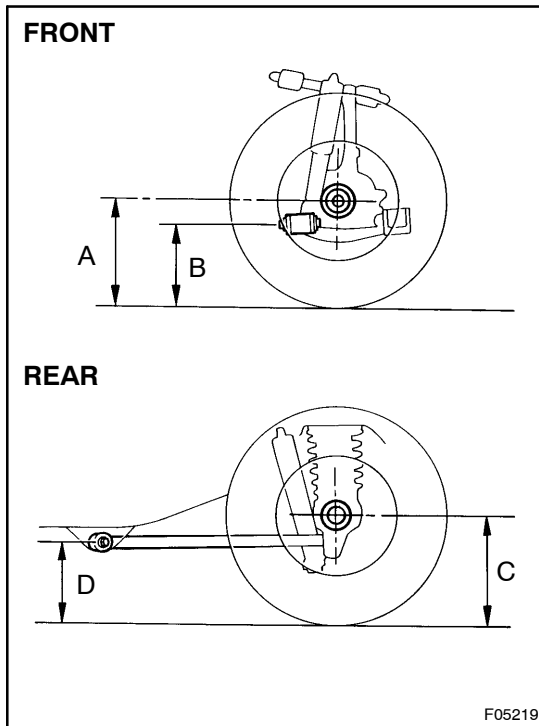

2. ADJUST HEIGHT CONTROL SENSOR (IN CASE OF NOT USING LEXUS HAND-HHELD TESTER)

- (a) Inspect the vehicle height.

Vehicle height

Front	A - B: 82.7 mm (3.256 in.)
Rear	C - D: 71.2 mm (2.803 in.)

Measuring points:

A: Ground clearance of spindle center

B: Ground clearance of lower suspension arm front bolt center

C: Ground clearance of rear axle shaft center

D: Ground clearance of lower control arm front bolt center

- (b) Inspect and adjust the height control sensor to the neutral position.

- (1) Disconnect the connector of front and rear height control sensors.

- (2) Connect 3 dry cell batteries of 1.5 V to SHB terminal and its negative to SHG terminal and apply approx. 4.5 V voltage between the terminals.

- (3) Measure the voltage between terminals SHB and SHG. The target voltage (Voltage between SHFL, SHFR, SHRR and SHB) can be obtained by dividing this value by 2.

HINT:

(Example)

Terminal voltage between SHB and SHG: 4.5 V

Target voltage: 2.25 V

- (4) Measure the voltage between SHFL (SHFR, SHRR) and SHG terminals when voltage is applied.

Standard value:

Front sensor: Target voltage \pm 0.08 V

Rear sensor: Target voltage \pm 0.07 V

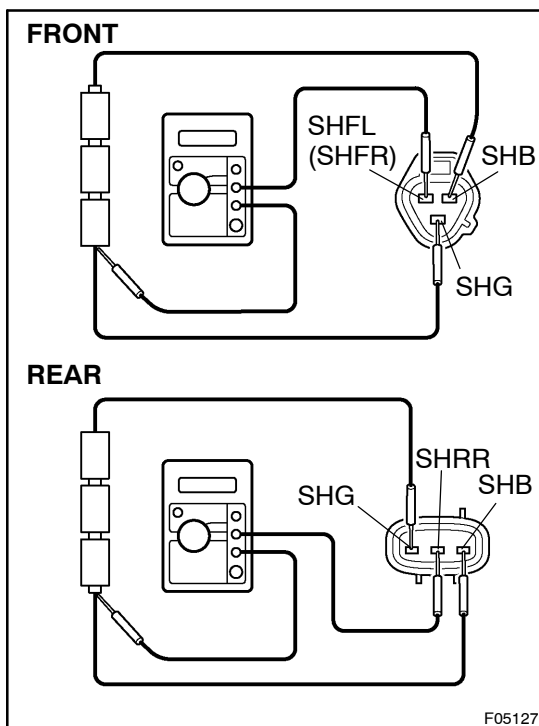

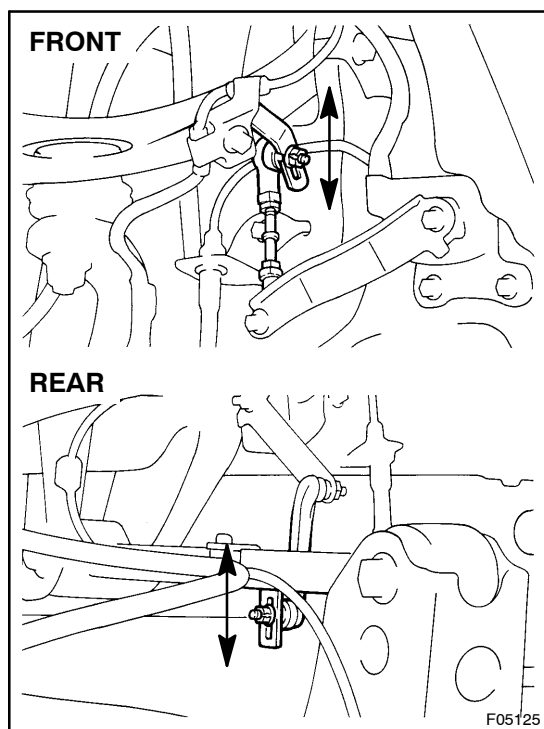

- (5) Loosen the nut and adjust the positions of the height control sensor link and front upper suspension arm or rear lower control arm by moving them up and down to install them.
- (6) Tighten the nut.

Torque: 5.6 N·m (57 kgf·cm, 49 in.·lbf)

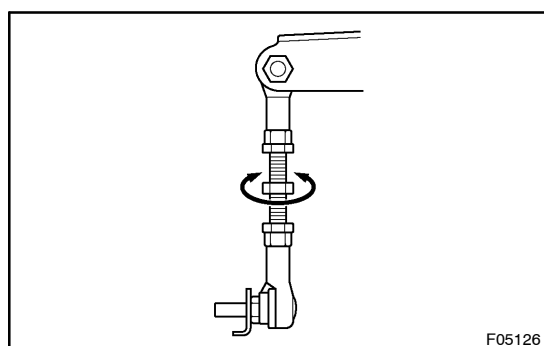

- (7) Front sensor:
When adjustment cannot be done by performing step (5), loosen the 2 nuts of height control sensor link and turn the link.

HINT:

- To raise the vehicle, turn the link clockwise.
- To lower the vehicle, turn the link counterclockwise.

- (8) Tighten the 2 nuts.

Torque: 5.4 N·m (55 kgf·cm, 48 in.·lbf)

- (9) Coat the threads of the link with sealer.

Sealer:

Part No. 08833-00070, THREE BOND 1324 or equivalent

3. ADJUST TORSION BAR SPRING (IN CASE OF USING LEXUS HAND-HELD TESTER)

NOTICE:

- Perform the operation with vehicle unloaded (with the fuel tank filled up).
- Temperature should be normal.
(10 – 50 °C, 50 °F – 122 °F in the engine compartment)
- Perform this on a level place.

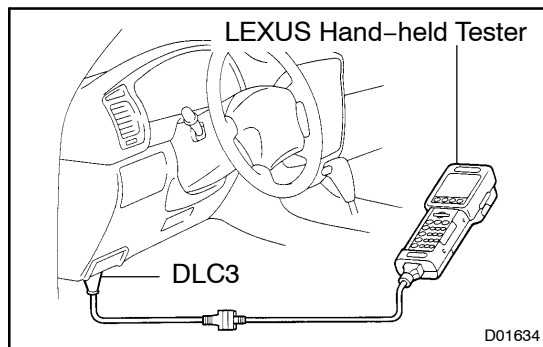

- (a) Connect the LEXUS hand-held tester to DLC3 on the vehicle.
- (b) Start the engine and push the height select switch to adjust the vehicle height to the "N" position.
- (c) With the ignition switch OFF, adjust the torsion bar spring so that the difference between right and left in vehicle height is less than 10 mm (0.39 in.).

HINT:

To reduce the difference between right and left is tightening amount of torsion bar spring, adjust the both sides by the same amount.

NOTICE:

Adjust it with no passengers are in.

- (d) Start the engine and push the height select switch to adjust the vehicle height from the "N" to "LO" then back to "N" position.
- (e) Stop the engine.
- (f) Read the pressure value of the front shock absorber with LEXUS hand-held tester at this time.

Pressure:

6.9 ± 0.5 MPa (70 ± 5 kgf/cm², 996 ± 71 psi)

HINT:

The cylinder pressure read by the LEXUS hand-held tester is estimated by the pump emitted pressure so the pressure is approx. 1.2 MPa (12 kgf/cm², 171 psi) higher than the pressure read by the LSPV gauge (SST).

If the value is not within the specification, adjust the torsion bar spring.

NOTICE:

Make sure to turn the ignition OFF when adjusting the torsion bar spring.

HINT:

- Approx. 0.2 MPa (2 kgf/cm², 28 psi) changes when both right and left adjusting bolts are turned one turn.
- The pressure rises when the adjusting bolts are loosened.

Pressure:

6.9 ± 0.3 MPa (70 ± 3 kgf/cm², 996 ± 43 psi)

- (g) Start the engine and push the height select switch to adjust the vehicle height to the "N" position.
- (h) Check the fluid level (See page [SA-130](#)).

4. ADJUST TORSION BAR SPRING (IN CASE OF NOT USING LEXUS HAND-HELD TESTER)

NOTICE:

- Perform the operation with the vehicle unloaded (with the fuel tank filled up).
 - After and before using LSPV gauge (SST), make sure to clean the hose, gauge and adopter.
- (a) Start the engine and push the height select switch to adjust the vehicle height to the "LO" position.
 - (b) With the ignition switch OFF, discharge the suspension fluid AHC from the bleeder plug of the either front right or left wheel dumping force control actuator.

CAUTION:

The fluid gushes out because of high pressure, so discharge the fluid in the same way as air bleeding.

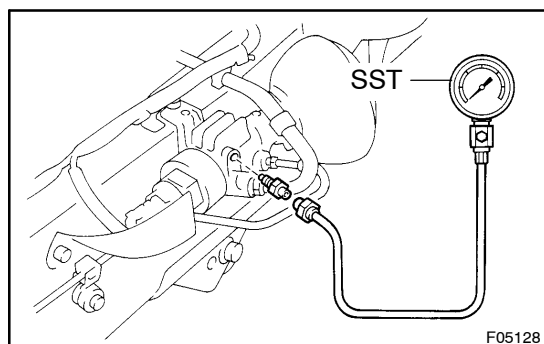

- (c) Remove the bleeder plug of either right or left dumping force control actuator and install the LSPV gauge (SST).
SST 09709-29018
- (d) Start the engine and push the height select switch to adjust the vehicle height to the "N" position.
- (e) With the ignition switch OFF, adjust the torsion bar spring so that the difference between right and left in vehicle height is less than 10 mm (0.39 in.).

HINT:

To reduce the difference between right and left of the torsion bar spring, tighten the same amount for loosening.

- (f) Start the engine and push the height select switch to adjust the vehicle height from the "N" to "LO" then back to "N" position.
- (g) Stop the engine.
- (h) Read the pressure value with LSPV gauge (SST) at this time.

SST 09709-29018

Pressure:

5.7 ± 0.3 MPa (58 ± 3 kgf/cm², 825 ± 43 psi)

If the value is not within the specification, adjust the torsion bar spring.

NOTICE:

Make sure to turn the ignition OFF when adjusting the torsion bar spring.

HINT:

- Approx. 0.2 Mpa (2 kgf/cm², 28 psi) changes when both right and left adjusting bolts are turned one turn.
- The pressure rises when the adjusting bolts are loosened.

- (i) Start the engine and push the height select switch to adjust the vehicle height to the "LO" position.
- (j) With the ignition switch OFF, discharge the suspension fluid AHC from the bleeder plug of LSPV gauge (SST).
SST 09709-29018

CAUTION:

The fluid gushes out because of high pressure, so discharge the fluid in the same way as air bleeding.

- (k) Remove the LSPV gauge (SST).
SST 09709-29018
- (l) Install the bleeder plug.
Torque: 8.3 N·m (84 kgf·cm, 73 in·lbf)
- (m) Bleed the air (See page [SA-129](#)).

HINT:

Bleed the bleeder plug with LSPV gauge (SST) installed to only once.

- (n) Check the fluid level (See page [SA-130](#)).